

## Pull handles antistatic

### Item description/product images



### Description

**Material:**

Thermoplastic PA (polyamide) reinforced.

**Version:**

graphite black.

**Note:**

The fastening hole is designed to accept the head of a cap or hexagon head screw or a hexagon nut.

**Application:**

Sensitive electrical or electronic equipment, components and devices (ESD sensitive elements) may be damaged or destroyed by electrostatic discharges (ESD) in the immediate vicinity.

Electrostatic discharges can come from people or through handling ESD sensitive components (e.g. during production, assembly, transport, storage etc).

Electrically conductive products which conform to DIN EN 61340-5-1 are essential within electronic environments to prevent an electrostatic discharge.

These products can be used for ESD applications or in ESD protection areas (EPA) in accordance with DIN EN 61340-5-1.

The yellow ESD logo is printed on the side of the product to clearly identify it.

**Assembly:**

From the front or rear.

**Safety:**

These ESD products can also be used for devices, components and protection systems in areas with high risk of explosion.

Use of these ESD products prevents the occurrence of electrostatic spark discharges, eliminating the potential ignition of gases and dusts which could lead to explosions in enclosed spaces.

Manufacturers and operators must use and conform to ATEX directives for the protection of persons working in areas with high risk of explosion.

These ESD products are certified by TÜV-Süd in relation to their electrical discharge capability.

**Target groups:**

Device manufacturers required to conform to ATEX product directive 2014/34/EU.

Operators required to conform to ATEX worker protection directive 1999/92/EC.

**Pull handles antistatic**

**Drawings**

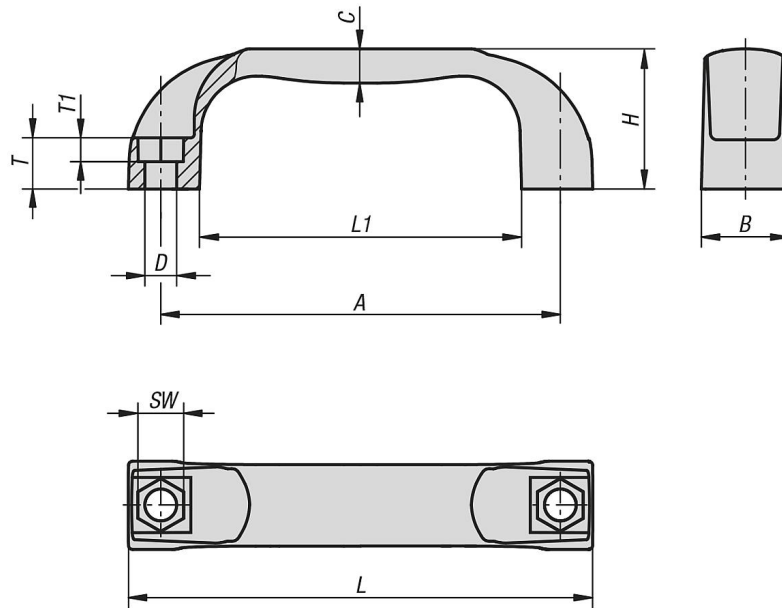

**Overview of items**

**Pull handles antistatic**

Order No.	Main colour	A	B	C	D	H	L	L1	SW	T	T1	Load capacity N
K0190.111170824	graphite black RAL 9011	117	26	10	9	41	136	94	13	15	8	1000