

Cam-action indexing plungers

Item description/product images

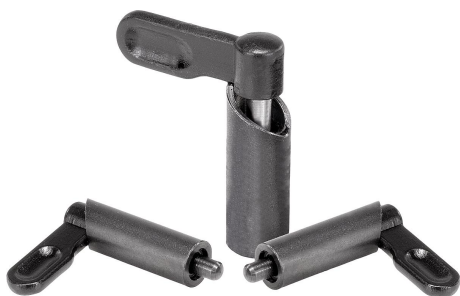

Description

Material:

Handle 1.0503.
Pin steel grade 5.8.
Sleeve 1.0403 weldable.

Version:

Black oxidised.
Pin hardened and ground.

Note:

Cam-action indexing plungers are used when the indexing pin should not project all the time. Turning the handle through 180° retracts the pin.

A notch ensures that the handle remains in this position.

To weld the plungers we recommend inert gas shielded welding with TIG welding equipment.

Drawings

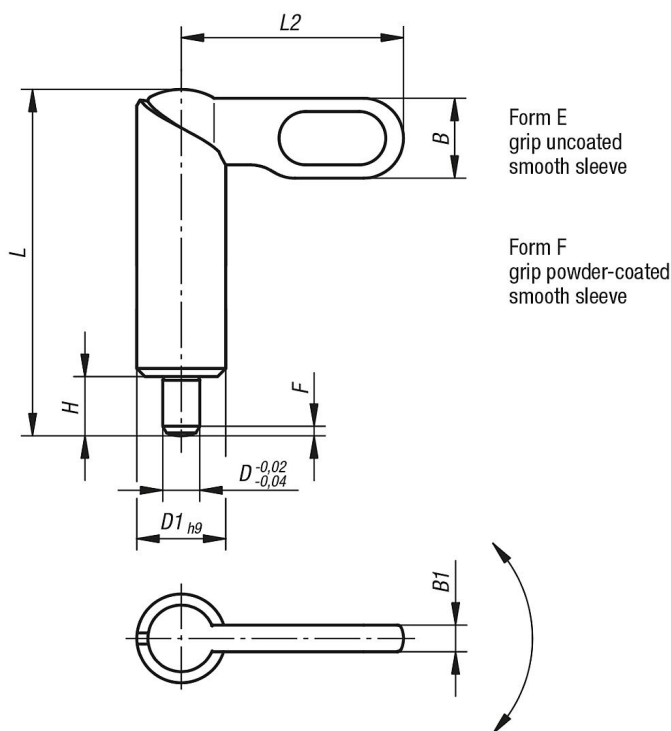

Overview of items

Cam-action indexing plungers

Order No.	Form	D	D1	L	L1	B	B1	H	Fx30°	Spring force initial pressure F1 approx. N	Spring force final pressure F2 approx. N
K0639.080410	E	4	10	38	25	9	3	6	1	8	14
K0639.080510	E	5	10	38	25	9	3	6	1,3	8	14
K0639.080610	E	6	10	38	25	9	3	6	1,8	8	14
K0639.080512	E	5	12	46,8	30	10,8	3,6	8	1,3	8	15

Cam-action indexing plungers

Overview of items

Order No.	Form	D	D1	L	L1	B	B1	H	Fx30°	Spring force initial pressure F1 approx. N	Spring force final pressure F2 approx. N
K0639.080612	E	6	12	46,8	30	10,8	3,6	8	1,8	8	15
K0639.080812	E	8	12	46,8	30	10,8	3,6	8	2,3	8	15
K0639.080616	E	6	16	60,4	40	14,4	4,8	10	1,8	15	35
K0639.080816	E	8	16	60,4	40	14,4	4,8	10	2,3	15	35
K0639.081016	E	10	16	60,4	40	14,4	4,8	10	2,8	15	35
K0639.080820	E	8	20	70	50	18	6	12	2,3	20	60
K0639.081020	E	10	20	70	50	18	6	12	2,8	20	60
K0639.081220	E	12	20	70	50	18	6	12	3	20	60
K0639.090410	F	4	10	38	25	9	3	6	1	8	14
K0639.090510	F	5	10	38	25	9	3	6	1,3	8	14
K0639.090610	F	6	10	38	25	9	3	6	1,8	8	14
K0639.090512	F	5	12	46,8	30	10,8	3,6	8	1,3	8	15
K0639.090612	F	6	12	46,8	30	10,8	3,6	8	1,8	8	15
K0639.090812	F	8	12	46,8	30	10,8	3,6	8	2,3	8	15
K0639.090616	F	6	16	60,4	40	14,4	4,8	10	1,8	15	35
K0639.090816	F	8	16	60,4	40	14,4	4,8	10	2,3	15	35
K0639.091016	F	10	16	60,4	40	14,4	4,8	10	2,8	15	35
K0639.090820	F	8	20	70	50	18	6	12	2,3	20	60
K0639.091020	F	10	20	70	50	18	6	12	2,8	20	60
K0639.091220	F	12	20	70	50	18	6	12	3	20	60