

Toggle clamps vertical with flat foot and full holding arm

Item description/product images



Description

Material:

Steel.

Version:

Trivalent passivated.
Plastic grip oil-resistant.

Note:

The opening angle between the holding arm and the handle can be reduced or increased by repositioning or removing the stop pin.
Spindle bracket is weldable.

Accessory:

K0098
K0100
K0101
K0102
K0103
K0106

Drawing reference:

1) stop pin position 1
2) stop pin position 2



Angle bracket for
front face mounting
(see accessories)

Toggle clamps vertical with flat foot and full holding arm

Drawings

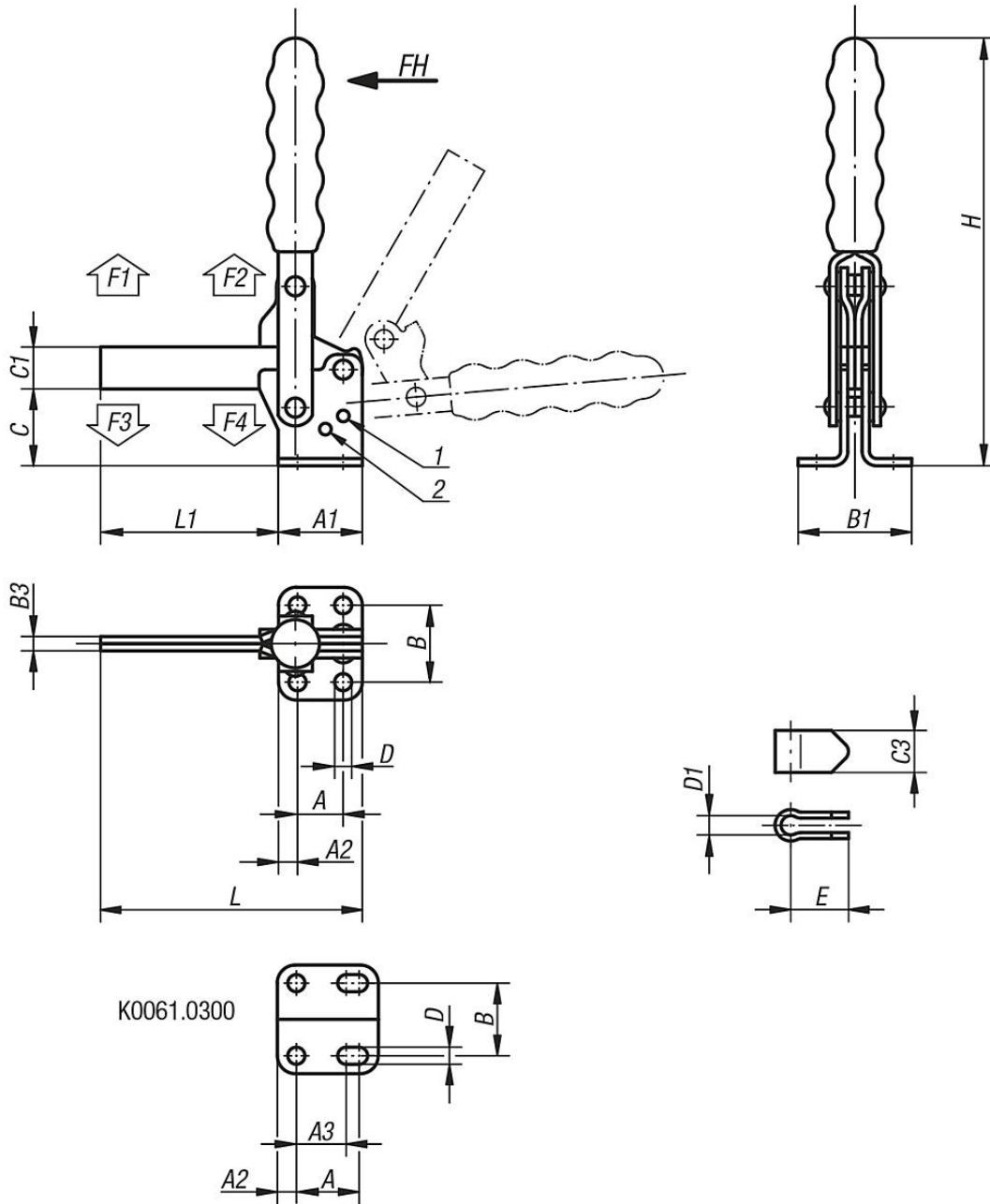

Overview of items

Toggle clamps vertical with flat foot and full holding arm

Order No.	Opening angle holding arm position 1	Opening angle holding arm position 2	Opening angle holding arm stop pin removed	Opening angle handle position 1	Opening angle handle position 2	Opening angle handle stop pin removed	Order No. Angle bracket	Matching plastic grip														
K0061.0250	95°	125°	160°	70°	85°	100°	K0098.04	K0100.28														
K0061.0300	105°	-	160°	65°	-	90°	-	K0100.28														
K0061.0350	90°	120°	180°	70°	80°	110°	K0098.06	K0100.30														
K0061.0450	90°	125°	180°	70°	85°	110°	K0098.06	K0100.34														
K0061.0550	90°	120°	180°	65°	80°	110°	-	K0100.35														
Order No.	A	A1	A2	A3	B	B1	B3	C	C1	C3	D	D1	E	H	L	L1	Clamping spindle	Hand force FH N	Retaining force F1 N	Retaining force F2 N	Clamping force F3 N	Clamping force F4 N
K0061.0250	19	35	8	-	32	47	6	31	17,5	17,5	7,1	8,3	24	175	112	77	M8x60	190	1000	2800	900	1700

Toggle clamps vertical with flat foot and full holding arm

Overview of items

Order No.	A	A1	A2	A3	B	B1	B3	C	C1	C3	D	D1	E	H	L	L1	Clamping spindle	Hand force FH N	Retaining force F1 N	Retaining force F2 N	Clamping force F3 N	Clamping force F4 N
K0061.0300	25	43	9	19	34,5	52	6	34	19	17,5	8	8,3	24	186	143	100	M8x60	130	2000	3700	900	1850
K0061.0350	32	50	9	-	45	64	8	42	22	22	8,3	10,3	30	220	149	99	M10x80	230	2200	4500	1400	3000
K0061.0450	32	53	10	-	45	64	10	51	25	26	8,7	12,3	32	228	180	127	M12x100	260	3200	7000	1400	3000
K0061.0550	51	76	12,5	-	70	95	10	84	32	32	12,3	16,3	35	312	236	160	M16x150	290	3000	8000	1800	3900