

Self-aligning pads with O-ring and exchangeable inserts, Form C, flattened steel insert smooth

Item description/product images



Description

Material:

Body carbon steel.

Ball rust and acid resistant steel.

Insert:

Form C tool steel.

Version:

Body tempered and black oxidised.

Ball hardened, bright.

Insert:

Form C hardened and black oxidised.

Note:

Self-aligning pads are used to support and clamp unmachined and machined workpieces.

They can also be used as stops, supports and thrust pads in fixtures and toolmaking.

The ball can be removed from the housing by applying light pressure to the socket head screw.

Ball secured against rotation.

Advantages:

Highly cost-effective as inserts can be exchanged.

The built-in O-ring holds the ball in place and keeps dirt and foreign particles out, ensuring uniform movement.

Self-aligning pads with O-ring and exchangeable inserts, Form C, flattened steel insert smooth

Drawings

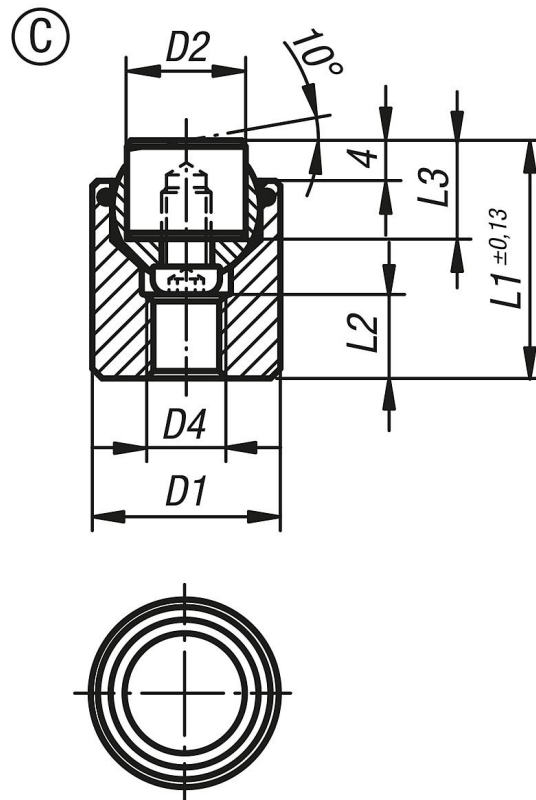

Overview of items

Order No.	Form	D1	D2	D4	L1	L2	L3	Ball Ø	Load rating max. kN (static load only)	Order No. steel insert
K0285.117X022	C	17	10	M6	22	7	10	13	28	K0385.10108
K0285.119X024	C	19	12	M8	24	8	10	15	39	K0385.12108
K0285.124X028	C	24	16	M10	28	8	10	20	58	K0385.16108
K0285.130X030	C	30	20	M12	30	9	10	23	95	K0385.20108
K0285.136X036	C	36	25	M12	36	11	10	28	136	K0385.25108