

## Indexing plungers without collar

### Item description/product images

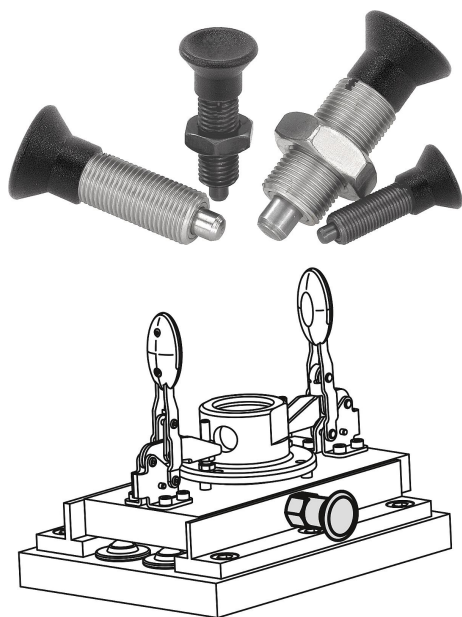

### Description

#### Material:

Steel version

Indexing pin hardened:  
grade 5.8.

Stainless steel version

Indexing pin hardened:  
Threaded sleeve 1.4305.  
Indexing pin 1.4034.

Indexing pin not hardened:

Threaded sleeve 1.4305.  
Indexing pin 1.4305.

Mushroom knob black-grey thermoplastic.

#### Version:

Steel version:

Indexing pin hardened, ground, black oxidised.

Stainless steel version:

Indexing pin hardened, ground and bright.

Indexing pin not hardened, ground and bright.

#### Note:

Indexing plungers are used to prevent any change in locking position due to lateral forces. A new locking position can only be set after the pin has been manually disengaged.

A washer is available to aid by screwing in the indexing plungers. The washer slides beneath the mushroom knob so that the carrier pins engage in the slot.

#### On request:

Special versions.

# Indexing plungers without collar

## Drawings

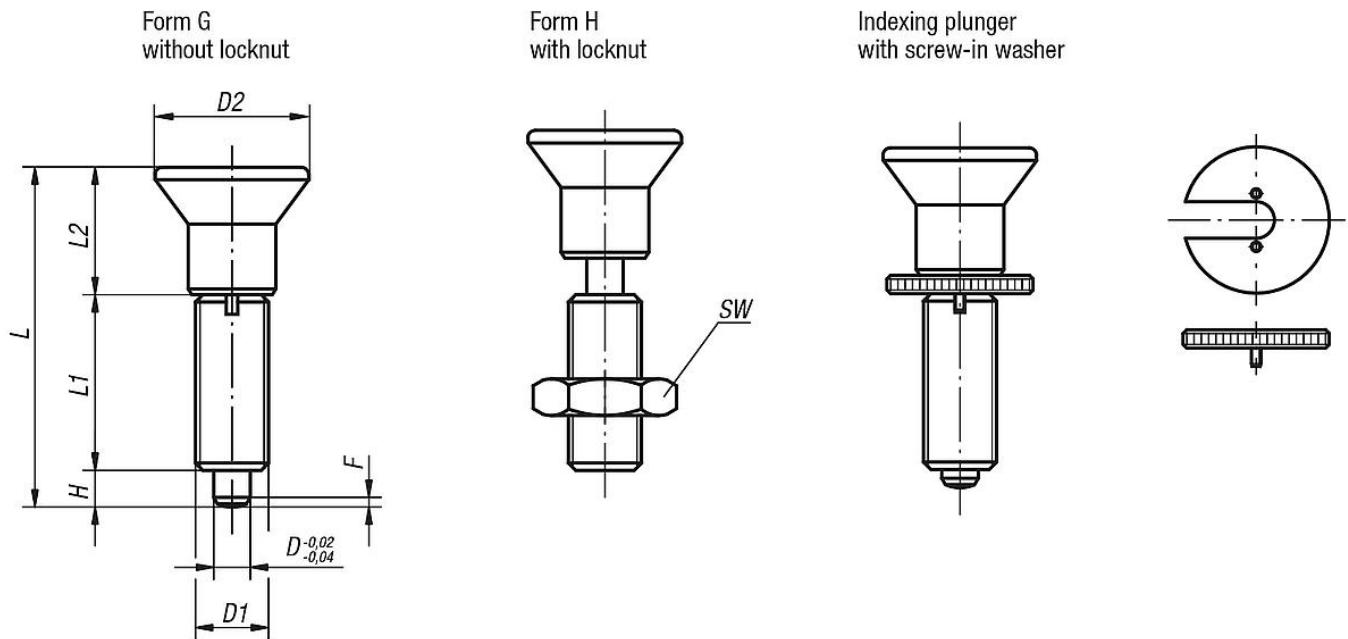

## Overview of items

### Indexing plungers without collar, steel, indexing pin hardened

Order No. Form G	Order No. Form H	D	D1	D2	L	L1	L2	H	SW	Fx30°	Spring force initial pressure F1 approx. N	Spring force final pressure F2 approx. N	Order No. screw-in washer
K0343.1903	K0343.2903	3	M6x0,75	14	31,5	17	11	3,5	- / 10	0,8	4,5	10	K0344.99
K0343.1004	K0343.2004	4	M8x1	18	38,5	21	13,5	4	- / 13	1,3	6	12	K0344.90
K0343.1105	K0343.2105	5	M10x1	21	43,5	24	14,5	5	- / 17	1,3	5	12	K0344.91
K0343.1206	K0343.2206	6	M12x1,5	25	51,7	28	17,7	6	- / 19	1,8	6	14	K0344.92
K0343.1308	K0343.2308	8	M16x1,5	33	68	36	24	8	- / 24	2,3	15	35	K0344.93
K0343.1410	K0343.2410	10	M20x1,5	33	74	40	24	10	- / 30	2,8	15	34	K0344.94
K0343.1412	K0343.2412	12	M20x1,5	33	78	42	24	12	- / 30	2,8	15	39	K0344.94
K0343.1516	K0343.2516	16	M24x2	40	96	50	30	16	- / 36	3,2	20	46	K0344.95

### Indexing plungers without collar, stainless steel, indexing pin hardened

Order No. Form G	Order No. Form H	D	D1	D2	L	L1	L2	H	SW	Fx30°	Spring force initial pressure F1 approx. N	Spring force final pressure F2 approx. N	Order No. screw-in washer
K0343.01903	K0343.02903	3	M6x0,75	14	31,5	17	11	3,5	- / 10	0,8	4,5	10	K0344.99
K0343.01004	K0343.02004	4	M8x1	18	38,5	21	13,5	4	- / 13	1,3	6	12	K0344.90
K0343.01105	K0343.02105	5	M10x1	21	43,5	24	14,5	5	- / 17	1,3	5	12	K0344.91
K0343.01206	K0343.02206	6	M12x1,5	25	51,7	28	17,7	6	- / 19	1,8	6	14	K0344.92
K0343.01308	K0343.02308	8	M16x1,5	33	68	36	24	8	- / 24	2,3	15	35	K0344.93
K0343.01410	K0343.02410	10	M20x1,5	33	74	40	24	10	- / 30	2,8	15	34	K0344.94
K0343.01412	K0343.02412	12	M20x1,5	33	78	42	24	12	- / 30	2,8	15	39	K0344.94
K0343.01516	K0343.02516	16	M24x2	40	96	50	30	16	- / 36	3,2	20	46	K0344.95

### Indexing plungers without collar, stainless steel, indexing pin not hardened

Order No. Form G	Order No. Form H	D	D1	D2	L	L1	L2	H	SW	Fx30°	Spring force initial pressure F1 approx. N	Spring force final pressure F2 approx. N	Order No. screw-in washer
K0343.11903	K0343.12903	3	M6x0,75	14	31,5	17	11	3,5	- / 10	0,8	4,5	10	K0344.99
K0343.11004	K0343.12004	4	M8x1	18	38,5	21	13,5	4	- / 13	1,3	6	12	K0344.90
K0343.11105	K0343.12105	5	M10x1	21	43,5	24	14,5	5	- / 17	1,3	5	12	K0344.91
K0343.11206	K0343.12206	6	M12x1,5	25	51,7	28	17,7	6	- / 19	1,8	6	14	K0344.92
K0343.11308	K0343.12308	8	M16x1,5	33	68	36	24	8	- / 24	2,3	15	35	K0344.93

## Indexing plungers without collar

### Overview of items

Order No. Form G	Order No. Form H	D	D1	D2	L	L1	L2	H	SW	Fx30°	Spring force initial pressure F1 approx. N	Spring force final pressure F2 approx. N	Order No. screw-in washer
K0343.11410	K0343.12410	10	M20x1,5	33	74	40	24	10	- / 30	2,8	15	34	K0344.94
K0343.11412	K0343.12412	12	M20x1,5	33	78	42	24	12	- / 30	2,8	15	39	K0344.94
K0343.11516	K0343.12516	16	M24x2	40	96	50	30	16	- / 36	3,2	20	46	K0344.95