

Handwheels with revolving grip

Item description/product images



Description

Material:

Black grey thermoplastic.

Version:

Steel parts black oxidised.

Note:

The hub cover and the revolving cylinder grip are supplied unassembled. To assemble, screw the grip into the tapped hole.

The handwheels can be secured using a transverse pin or by parallel key connection together with a DIN 6912 socket head screw and a DIN 7349 washer.

Versions with transverse bore are secured using the ISO 4027 (DIN 914) grub screw.

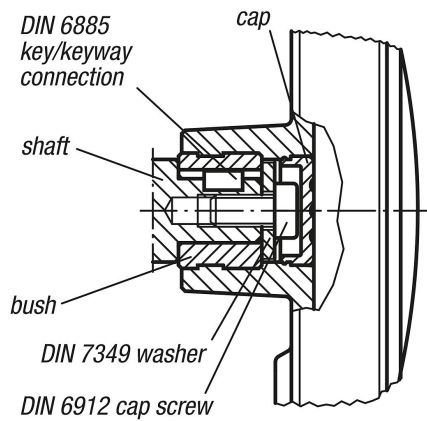

Handwheels with revolving grip

Drawings

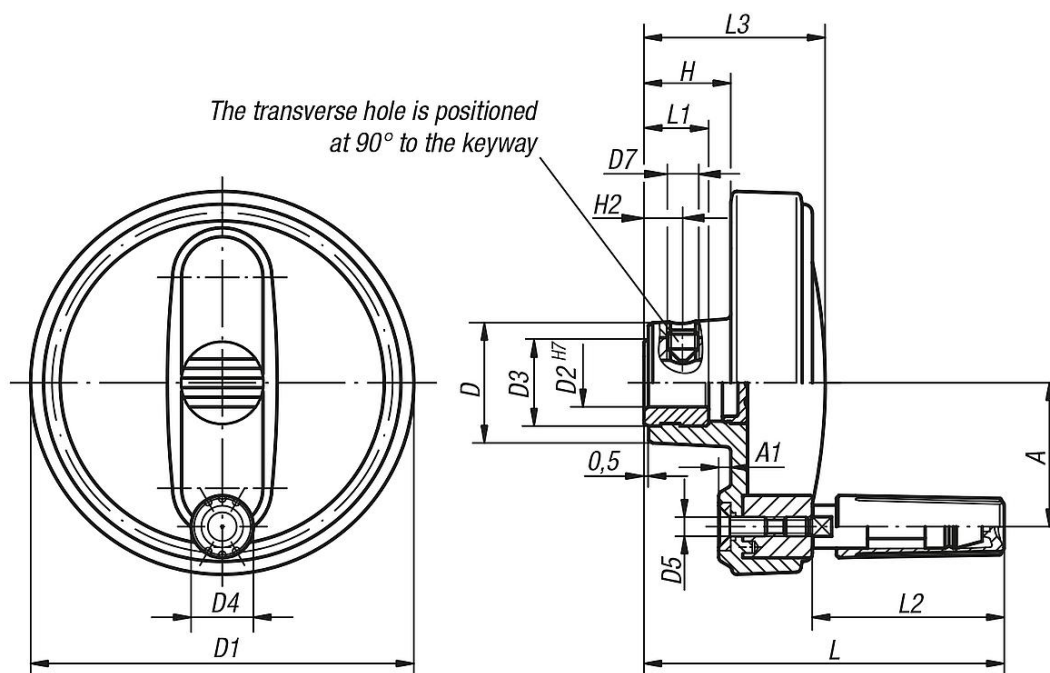

DIN 6885-1

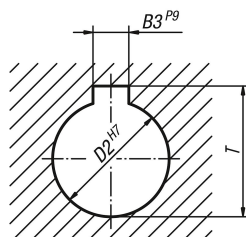

Overview of items

Handwheels with revolving cylinder grip

Order No.	Version	Type	D	D1	D2	D3	D4	D5	D7	A	A1	H	H2	L	L1	L2	L3	B3	T
K0257.108008	reamed hole	-	25	80	8H7	19	13	M4	-	30	2,5	17,5	-	75	13	40	37,5	-	-
K0257.108010	reamed hole	-	25	80	10H7	19	13	M4	-	30	2,5	17,5	-	75	13	40	37,5	-	-
K0257.108012	reamed hole	-	25	80	12H7	19	13	M4	-	30	2,5	17,5	-	75	13	40	37,5	-	-
K0257.210010	reamed hole	-	28	100	10H7	19	16	M5	-	38	3	20	-	90	13	49,5	44	-	-
K0257.210012	reamed hole	-	28	100	12H7	19	16	M5	-	38	3	20	-	90	13	49,5	44	-	-
K0257.312512	reamed hole	-	35	125	12H7	25	20	M6	-	47,5	4	23,5	-	109	18,5	60	53	-	-
K0257.312514	reamed hole	-	35	125	14H7	25	20	M6	-	47,5	4	23,5	-	109	18,5	60	53	-	-
K0257.312516	reamed hole	-	35	125	16H7	25	20	M6	-	47,5	4	23,5	-	109	18,5	60	53	-	-
K0257.416014	reamed hole	-	45	160	14H7	25	25	M8	-	62	5,6	28	-	144	18,5	83,5	64,5	-	-
K0257.416016	reamed hole	-	45	160	16H7	25	25	M8	-	62	5,6	28	-	144	18,5	83,5	64,5	-	-
K0257.10800802	reamed hole with slot	-	25	80	8H7	19	13	M4	-	30	2,5	17,5	-	75	13	40	37,5	2	9
K0257.10801003	reamed hole with slot	-	25	80	10H7	19	13	M4	-	30	2,5	17,5	-	75	13	40	37,5	3	11,4
K0257.10801204	reamed hole with slot	-	25	80	12H7	19	13	M4	-	30	2,5	17,5	-	75	13	40	37,5	4	13,8
K0257.21001003	reamed hole with slot	-	28	100	10H7	19	16	M5	-	38	3	20	-	90	13	49,5	44	3	11,4
K0257.21001204	reamed hole with slot	-	28	100	12H7	19	16	M5	-	38	3	20	-	90	13	49,5	44	4	13,8
K0257.31251204	reamed hole with slot	-	35	125	12H7	25	20	M6	-	47,5	4	23,5	-	109	18,5	60	53	4	13,8
K0257.31251405	reamed hole with slot	-	35	125	14H7	25	20	M6	-	47,5	4	23,5	-	109	18,5	60	53	5	16,3
K0257.31251605	reamed hole with slot	-	35	125	16H7	25	20	M6	-	47,5	4	23,5	-	109	18,5	60	53	5	18,3
K0257.41601405	reamed hole with slot	-	45	160	14H7	25	25	M8	-	62	5,6	28	-	144	18,5	83,5	64,5	5	16,3
K0257.41601605	reamed hole with slot	-	45	160	16H7	25	25	M8	-	62	5,6	28	-	144	18,5	83,5	64,5	5	18,3

Handwheels with revolving grip

Overview of items

Order No.	Version	Type	D	D1	D2	D3	D4	D5	D7	A	A1	H	H2	L	L1	L2	L3	B3	T
K0257.2100126	reamed hole	with transverse bore	28	100	12H7	19	16	M5	M6	38	3	20	7,5	90	13	49,5	44	-	-
K0257.3125126	reamed hole	with transverse bore	35	125	12H7	25	20	M6	M6	47,5	4	23,5	7,5	109	18,5	60	53	-	-
K0257.3125146	reamed hole	with transverse bore	35	125	14H7	25	20	M6	M6	47,5	4	23,5	7,5	109	18,5	60	53	-	-
K0257.3125166	reamed hole	with transverse bore	35	125	16H7	25	20	M6	M6	47,5	4	23,5	7,5	109	18,5	60	53	-	-
K0257.4160146	reamed hole	with transverse bore	45	160	14H7	25	25	M8	M6	62	5,6	28	7,5	144	18,5	83,5	64,5	-	-
K0257.4160166	reamed hole	with transverse bore	45	160	16H7	25	25	M8	M6	62	5,6	28	7,5	144	18,5	83,5	64,5	-	-
K0257.1080086	reamed hole	with transverse bore	25	80	8H7	19	13	M4	M6	30	2,5	17,5	7,5	75	13	40	37,5	-	-
K0257.1080106	reamed hole	with transverse bore	25	80	10H7	19	13	M4	M6	30	2,5	17,5	7,5	75	13	40	37,5	-	-
K0257.1080126	reamed hole	with transverse bore	25	80	12H7	19	13	M4	M6	30	2,5	17,5	7,5	75	13	40	37,5	-	-
K0257.2100106	reamed hole	with transverse bore	28	100	10H7	19	16	M5	M6	38	3	20	7,5	90	13	49,5	44	-	-
K0257.108008026	reamed hole with slot	with transverse bore	25	80	8H7	19	13	M4	M6	30	2,5	17,5	7,5	75	13	40	37,5	2	9
K0257.108010036	reamed hole with slot	with transverse bore	25	80	10H7	19	13	M4	M6	30	2,5	17,5	7,5	75	13	40	37,5	3	11,4
K0257.108012046	reamed hole with slot	with transverse bore	25	80	12H7	19	13	M4	M6	30	2,5	17,5	7,5	75	13	40	37,5	4	13,8
K0257.210010036	reamed hole with slot	with transverse bore	28	100	10H7	19	16	M5	M6	38	3	20	7,5	90	13	49,5	44	3	11,4
K0257.210012046	reamed hole with slot	with transverse bore	28	100	12H7	19	16	M5	M6	38	3	20	7,5	90	13	49,5	44	4	13,8
K0257.312512046	reamed hole with slot	with transverse bore	35	125	12H7	25	20	M6	M6	47,5	4	23,5	7,5	109	18,5	60	53	4	13,8
K0257.312514056	reamed hole with slot	with transverse bore	35	125	14H7	25	20	M6	M6	47,5	4	23,5	7,5	109	18,5	60	53	5	16,3
K0257.312516056	reamed hole with slot	with transverse bore	35	125	16H7	25	20	M6	M6	47,5	4	23,5	7,5	109	18,5	60	53	5	18,3
K0257.416014056	reamed hole with slot	with transverse bore	45	160	14H7	25	25	M8	M6	62	5,6	28	7,5	144	18,5	83,5	64,5	5	16,3
K0257.416016056	reamed hole with slot	with transverse bore	45	160	16H7	25	25	M8	M6	62	5,6	28	7,5	144	18,5	83,5	64,5	5	18,3